

**INSTALLATION
FORCE**

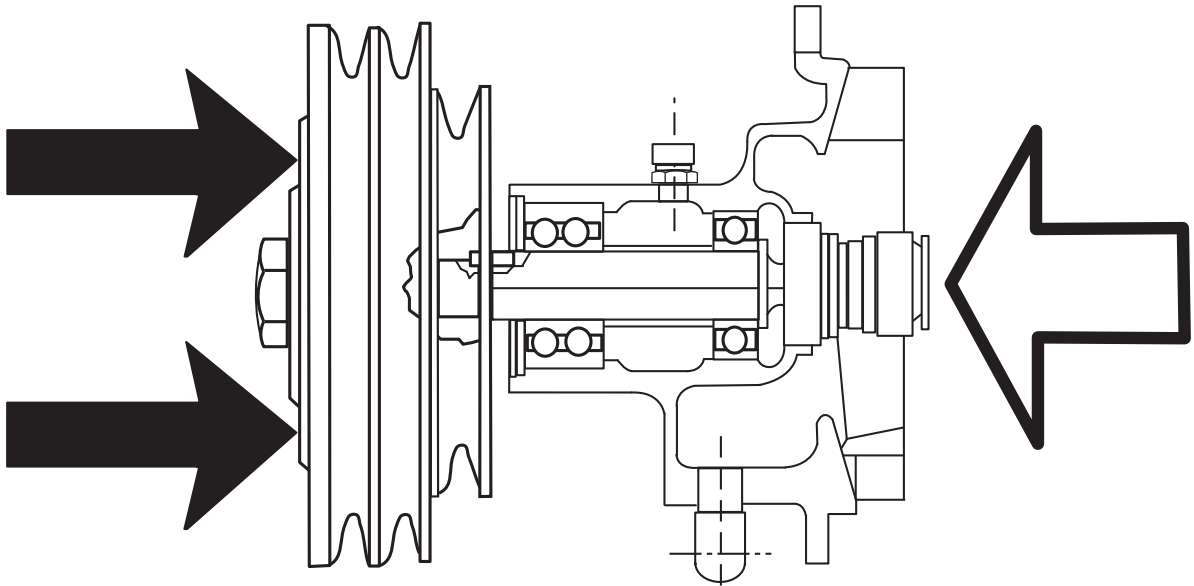

SUPPORT

CAUTION
WATER PUMP SHAFT MUST BE SUPPORTED
WHEN INSTALLING HUB OR PULLEY TO
PREVENT SEAL DAMAGE.



IIF1013 REV A



**SENTIDO DE LA FUERZA
DE INSTALACIÓN**

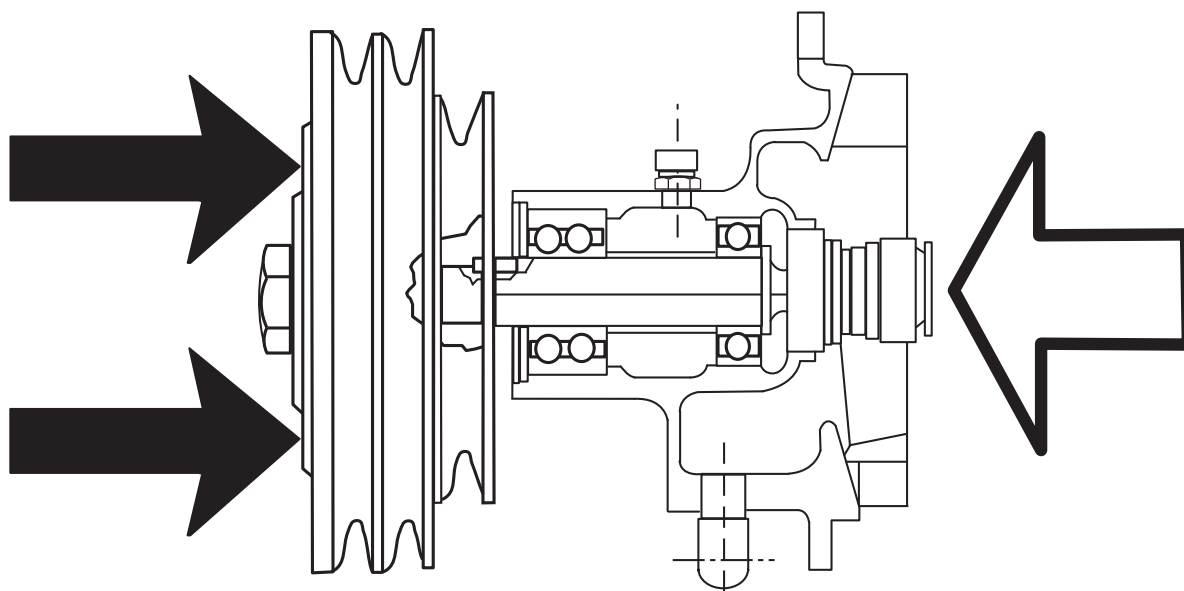

SOPORTE



ADVERTENCIA
EL EJE DE LA BOMBA DE AGUA DEBE SER
SOPORTADO O SOSTENIDO AL INSTALAR EL CUBO O LA POLEA
PARA PREVENIR DAÑO AL SELLO O A LA BOMBA

IIF1013 REV A

